



Handling System for Rack Type Trays Cord Conveyor Curve 45° with Legs

ITEM # _____

MODEL # _____

NAME # _____

SIS # _____

AIA # _____



865129 (HSCCT45C)

Cord conveyor for trays, 45°
curve Unit with legs

Short Form Specification

Item No. _____

Constructed in 304 AISI stainless steel. Two cords in 15mm reinforced polyurethane. Square 40x40mm tubular legs on height-adjustable feet. Designed for trays up to 375x530mm.

Main Features

- Range allows a large number of conveyor combinations.
- Wall mounted on request.
- Available as optional accessory a remote easy-to reach emergency-stop buttons fitted where required.
- Anti tray-jamming system.
- Other angles available on request.
- No stacking trays in curves increase the speed of the outside cord.

Construction

- For trays up to 375x530mm.
- All surfaces smooth with polished finish.
- Constructed in AISI 304 1,5mm stainless steel.
- Stainless steel square 40x40mm tubular legs.
- 15mm reinforced polyurethane cord, for smooth and easy running.
- Free-standing construction delivered with 40x40mm legs.
- Stainless steel plain conveyor base for easy cleaning.

Optional Accessories

- Emergency switch for cord conveyor PNC 865141
- Kit for cord welding PNC 865143

APPROVAL: _____



Experience the Excellence
www.electroluxprofessional.com

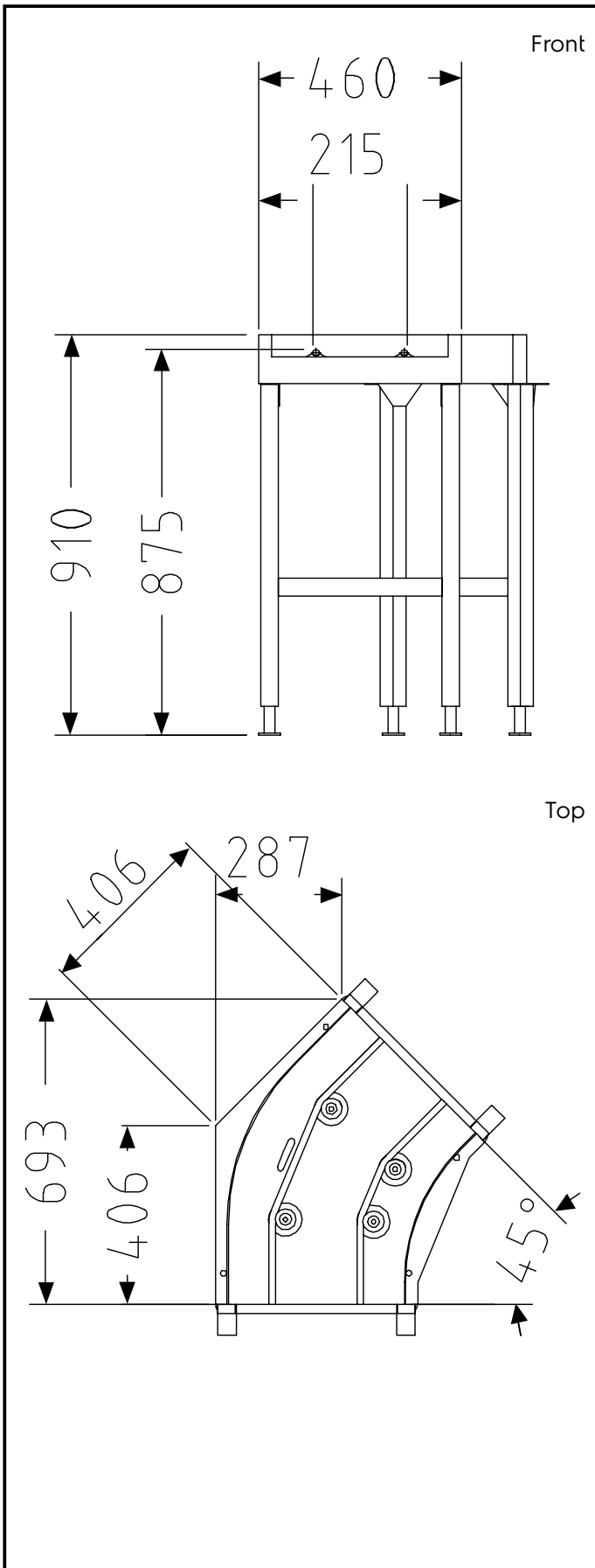

Key Information:

External dimensions, Width:	693 mm
865129 (HSCCT45C)	
External dimensions, Depth:	612 mm
External dimensions, Height:	910 mm
Net weight:	17 kg
Basin material:	Stainless Steel AISI 304 - EN 1.4301